

## Head Office & Showroom:

Suite 2.07 Wisma Academy  
Lot 4A Jalan 19/1  
46300 Petaling Jaya  
Selangor, Malaysia

Tel: +603-7958 2266  
Fax: +603-7958 3266

www.neosys.com  
info@neosys.com.my



# DigiCreaser

Fast, accurate and the best value quality creaser you can buy.

The Morgana manufactured DigiCreaser fills the gap between our manual machines and fully automatic machines like the best selling AutoCreaser Pro range.

## Creasing versus Scoring.

Traditional rotary scoring machines use circular blades that are in constant motion as the stock passes through them. This creates a ploughing action that actually cuts through the top fibres of the paper or card in order to create a score. Inevitably this weakens the paper and encourages cracking.

In contrast, the Morgana DigiCreaser employs a unique creasing rule and matrix as illustrated overleaf, that eliminates tearing and, therefore, cracking.

## Key Product Features

- **Fast & easy to setup**
- **Fully automatic after feeding**
- **Bench top with small footprint**
- **Takes stock up to 0.4mm (approx 400 gsm)\***
- **Rule and matrix guaranteed for life**
- **4000 sheets per hour**
- **Memory for storing repeat jobs**
- **Adjustable crease depth & square**
- **Perforating as standard**
- **Crease without cracking**

Whilst its cost is little over half that of an AutoCreaser, it offers exactly the same creasing quality and accuracy. This is because it uses an identical matrix and rule action, with the same technology to control both the positioning of the creases, but also to give a completely consistent creasing depth. With the rule and matrix manufactured from high quality tooled steel we can guarantee this mechanism for life.

In instances where the crease has to be set to an image which is not correctly registered you can swing the rule/matrix mechanism to compensate. The speed at which the sheets are taken into the in-put rollers can also be adjusted.

The DigiCreaser is no slouch when it comes to productivity. All functions are fully automatic after feeding and the unit can operate at speeds up to 4,000 sheets per hour. Up to 9 creases can be achieved in one pass and the sophisticated controls enable jobs to be stored and retrieved for repeat work.

The class leading specification of the DigiCreaser includes a maximum sheet size of 630mm x 330mm and it will handle weights of stock up to 0.4mm (approx 400 gsm)\* including laminated material.



The DigiCreaser has a Head-up display for greater ease of use. This is particularly intuitive as it provides the operator with a series of prompts which are actioned by a single controller. These include positioning of the creases, setting the speed of the machine, storing jobs and counting facility.

Standard features includes the same high quality perforating as the larger AutoCreasers. The perforating wheels are available with a variety of teeth to suit all applications.

The DigiCreaser can be supplied as either a bench top or floor standing model.

Picture shows optional base.

# DigiCreaser

Fast, accurate and the best value quality creaser you can buy.



## technical specifications

Maximum sheet size	630mm x 330mm
Minimum sheet size	140mm x 160mm
Maximum paper thickness	0.4mm (approx 400 gsm)* including laminated material
Minimum paper thickness	0.11mm (approx 80gsm)*
Maximum number of creases per sheet	9
Maximum number programmed applications	6
Minimum repeat crease distance	1mm (depending on paper weight)
Minimum crease distance from lead edge	25mm
Minimum crease distance from tail edge	20mm
Speed per hour (A4)	4000 sph (depending on operator)
Dimensions	L 870mm x W 570mm x H 590mm (1070mm on optional base)
Weight	57kgs (79kgs on optional base)
Power requirement	240v 50/60hz
Optional extras	Narrow creasing blade, Floor standing base

Note: the production speed varies according to material size and the number of creases on the sheet

**Creasing rule and matrix.** The DigiCreaser uses an identical mechanism to that on the more expensive AutoCreaser Pro 33 and DocuMaster Pro and is guaranteed for life. With thousands of these mechanisms installed throughout the world our creasing technology is unparalleled in both performance and longevity.

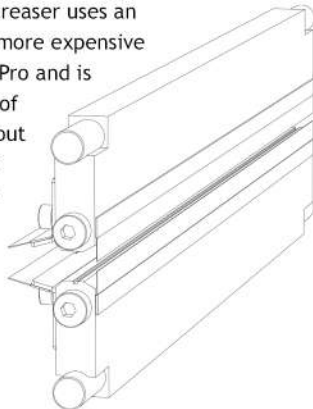

#### \*Disclaimer

As part of our continued product improvement plan, specifications and information published here are subject to change without notice.

All specifications are dependent on application, type of stock, temperature, RH and print engine used.

Specifications quoted were measured on uncoated and unprinted stock.

E & OE.